

DETAIL APPLICABILITY: STREETS OLDER THAN 10 YEARS

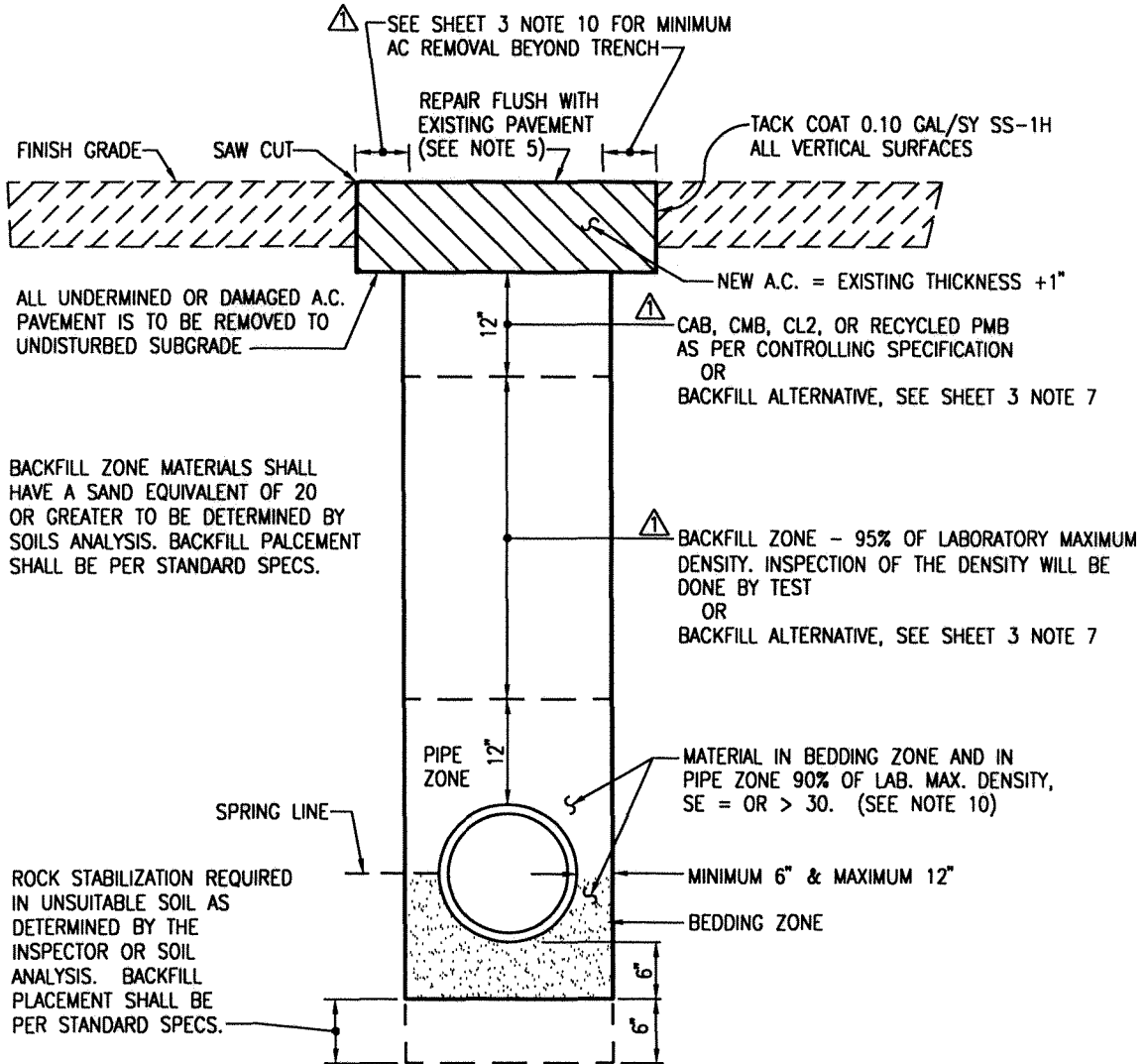

| | |
|------|------|
| REV. | DATE |
| | |
| | |
| | |

| | |
|------|------|
| REV. | DATE |
| | |
| | |
| | |

APPR. BY: Lou B. 7/31/06

| | | | |
|---|--|---|---------------------------|
|  | STD. TRENCH BACKFILL REQUIREMENT | | STANDARD PLAN 2002 |
| | DRAWN: A. ROQUE CKD.: B. STARR, PE Department of Public Works | APPR.  L. Boiderrama, PE, City Engineer | PLATE 602 SHEET 1 OF 3 |

DETAIL APPLICABILITY: STREETS LESS THAN 10 YEARS

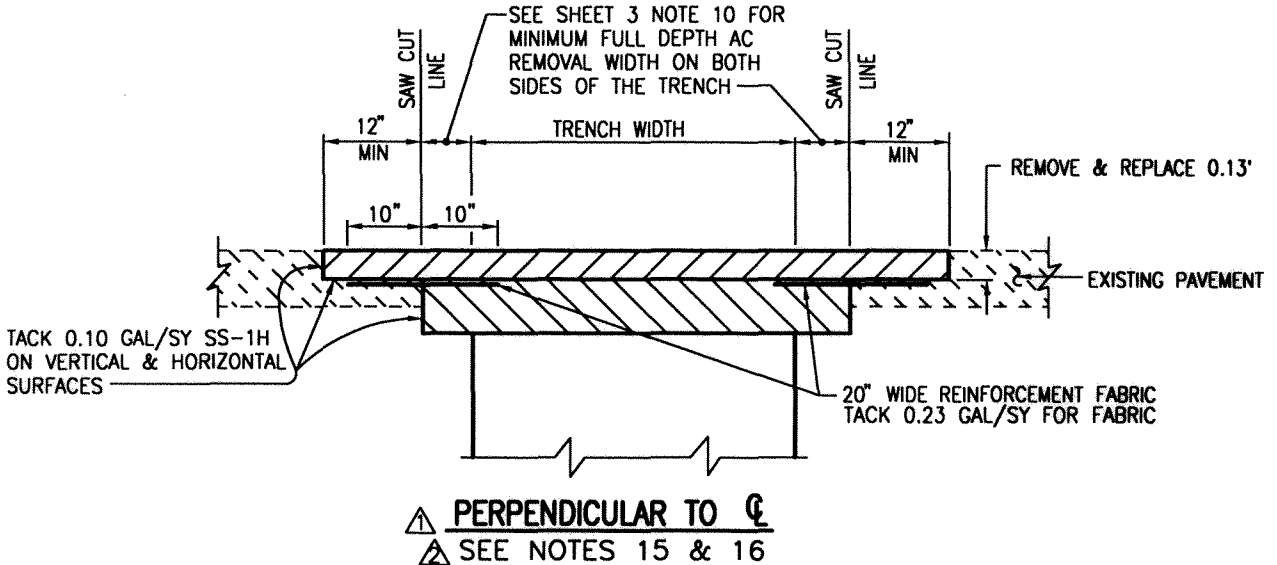
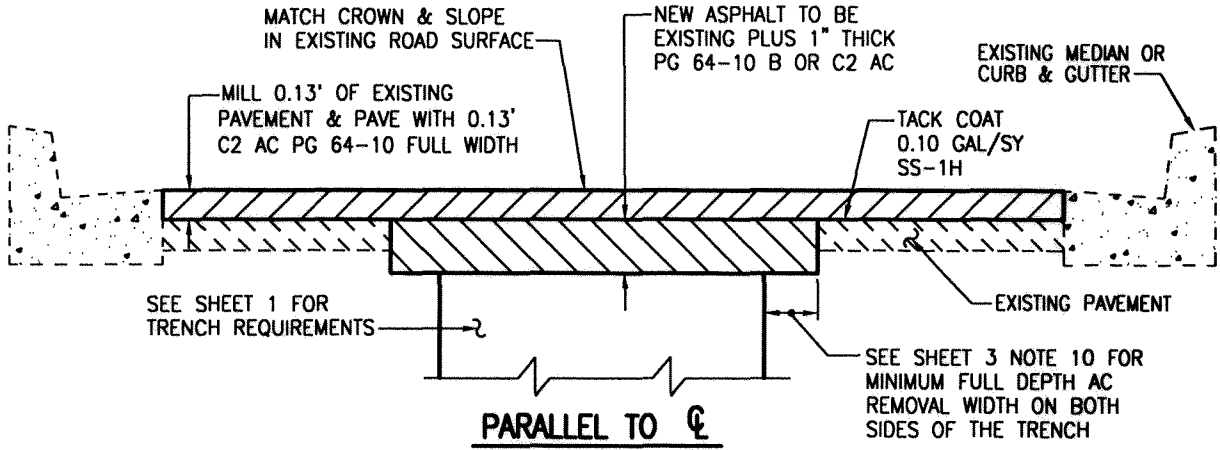

| | | |
|------|----------|------|
| REV. | APPR. BY | DATE |
| | | |

| | | |
|------|----------|---------|
| REV. | APPR. BY | DATE |
| | | |
| | Lou B. | 7/31/06 |
| | Lou B. | 9/28/06 |

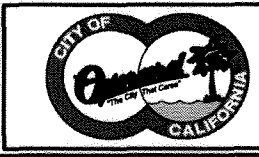

STD. TRENCH BACKFILL REQUIREMENT

DRAWN: A. ROQUE CKD.: B. STARR, PE
 Department of Public Works

APPR. *L. Balderrama*
 L. Balderrama, PE, City Engineer

STANDARD PLAN 2002
PLATE 602
 SHEET 2 OF 3

